

Merlin 1800

Zch.-Nr.: / drw. no.: 58058 page 1 of 2
 03.11.2020 B. Walther
 Maßstab / scale (DIN A3): 1:30
 sw-dat.: 58058-Merlin1800_SW_Standard_MB

Ausführung / Softwanne auf Rollen, GE: 0
 execution: juice tray on wheels
 Bac à jus sur roues
 Vasca mosto su ruote

Behältervolumen / Tank volume /
 Volume de la cuve / Volume serbatoio: 1.720 Liter

Füllvolumen der Softwanne / Juice tray volume /
 Bac à jus Contenu / Vasca mosto Capacità: 600 Liter

Leergewicht / Empty weight / Poids vide / Peso a vuoto:
 externer Kompressor / Integrierter Verdichter
 external compressor / integrated compressor 1320* / 1370* kg
 compressore esterno / compressore integrato

Willmes GmbH

Bensheimer Straße 101 - D-64653 Lorsch
 Service-Nummer: +49 1805 / 58 54 24
 www.willmes.de; e-mail: info@willmes.de

technische Änderungen vorbehalten / technical changes reserved /
 Sous réserve de modifications techniques / modifiche tecniche riservate
 Maßtoleranzen / dim. tolerances: L<4000mm: ±15mm; L>=4000mm: ±25mm
 Zeichnung kann von definitiver Ausführung gem. Auftragsbestätigung abweichen
 disegno può derogare del esecuzione definitivo secondo conferma d'ordine

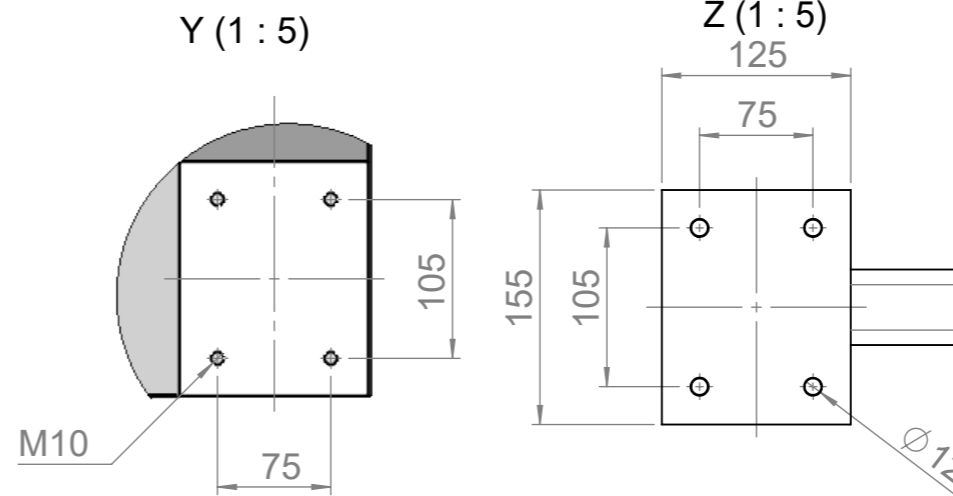
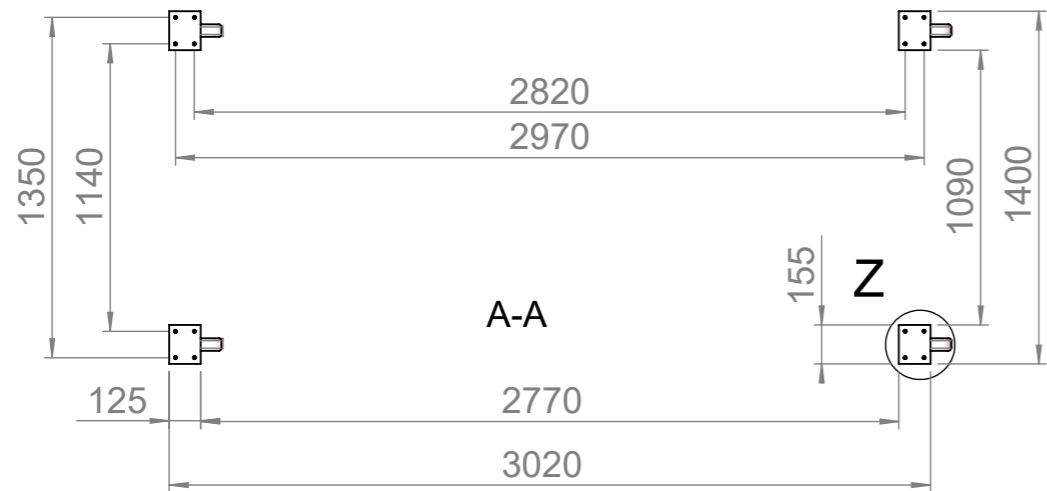
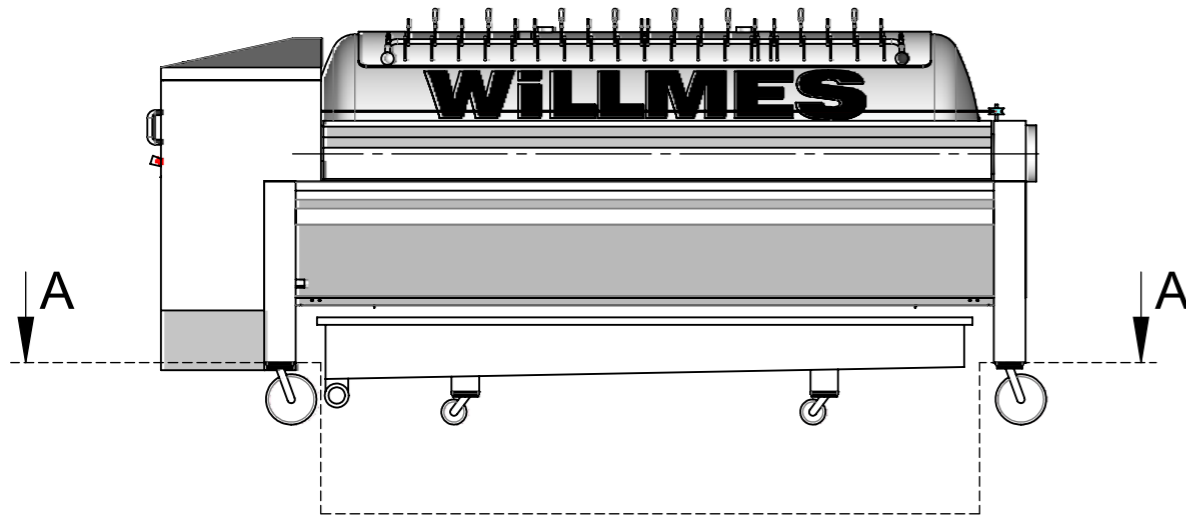
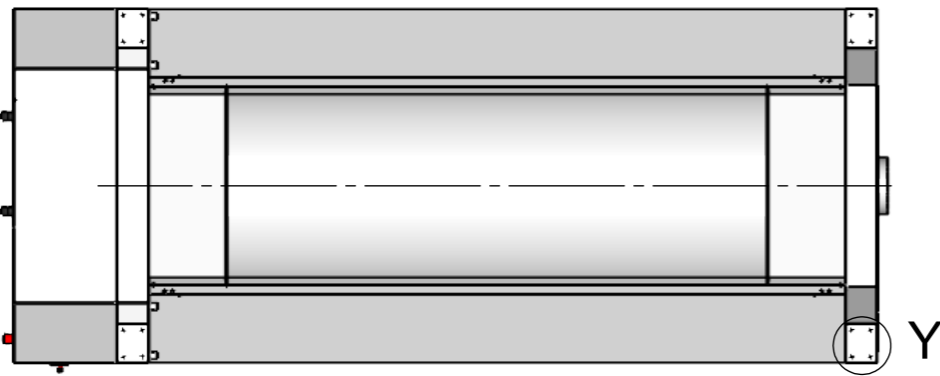

subject: forces upon installation

part: Merlin 1800 without additional options, completely filled (water!)

WILLMES

Datum / date: 01.01.2021

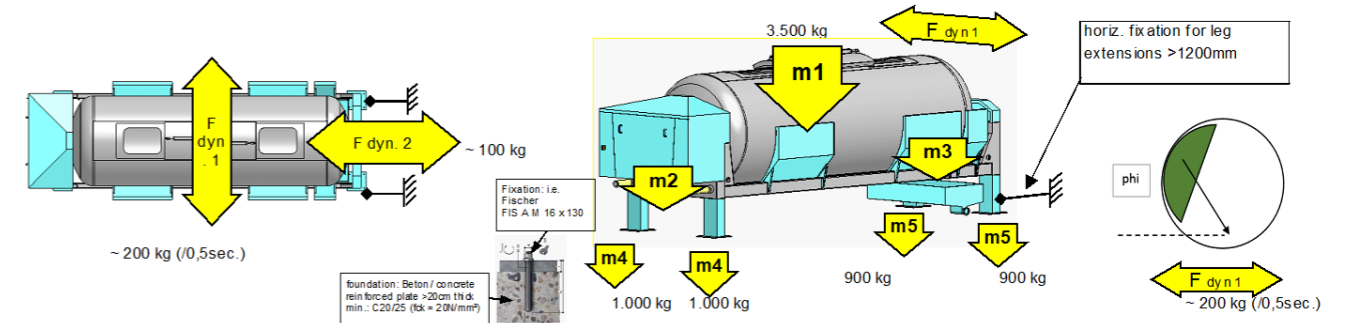

type of press: Merlin 1800

Leergewicht Presse ca. / empty weight / poids vide (net) / peso vuoto della pressa ca. 1.370 kg

Necessary condition for the installation and diverting of the forces of above-mentioned components plus the payloads is a sufficiently rigid and horizontal ground. We assume that this condition is met by the customer. Unless otherwise stated, expenses for any required static or dynamic calculation for total installation is not included. Expenses for any necessary tests in accordance with the local regulations or local regulatory approvals are not included.

Parameter	Wert / value / valeur / valore	Beschreibung / description / descrizione	Kraft / force / forza
m1	3.500 kg	Gesamtgewicht Presse + max. Füllung / total weight press + completely charged poids totale du pressoir + chargement / peso totale della pressa + caricamento	34 kN
m2	1.900 kg	Gesamtgewicht auf Antriebsseite / total weight drive end poids totale: côté moteur / peso totale: lato di motore	19 kN
m3	1.700 kg	Gesamtgewicht auf Gegenseite / total weight axial feed end poids totale: côté chargement axiale / peso totale: lato di alimentazione assiale	17 kN
m4 (2x)	1.000 kg	Gesamtgewicht pro Gestellfuß auf Motorseite / total weight per leg on drive end poids totale par pied au côté moteur / peso totale per piede al lato di motore	10 kN
m5 (2x)	900 kg	Gesamtgewicht pro Gestellfuß auf Gegenseite / total weight per leg on axial feed end poids totale par pied au côté chargement axiale / peso totale per piede al lato di caricamento assiale	9 kN
$F_{dyn 1}$	~ 200 kg (0,5sec.)	approx. horizontal force on rotation (pomace cake; frequency: ~ 5 x / pressing x ~ 3 pressings / day x ~ 30 days / year ~ 450x / year)	~ 1,3 kN (0,5sec.)
$F_{dyn 2}$	~ 100 kg	ATTENTION: in the case of central filling, dynamic vibration may be caused by mash pump	~ 1,0 kN

Merlin 1800

Zch.-Nr.: / drw. no.: 58058 page 2 of 2

03.11.2020 B. Walther

Maßstab / scale (DIN A3): 1:30

sw-dat.: 58058-Merlin1800_SW_Standard_MB

Ausführung / Softwanne auf Rollen, GE: 0

execution: juice tray on wheels

Bac à jus sur roues

Vasca mosto su ruote

Behältervolumen / Tank volume /
Volume de la cuve / Volume serbatoio:

1.720 Liter

Füllvolumen der Softwanne / Juice tray volume /
Bac à jus Contenu / Vasca mosto Capacità:

600 Liter

Leergewicht / Empty weight / Poids vide / Peso a vuoto:

externer Kompressor / Integrierter Verdichter
external compressor / integrated compressor
compressore esterno / compressore integrato

1320* / 1370* kg

Willmes GmbH

Bensheimer Straße 101 - D-64653 Lorsch

Service-Nummer: +49 1805 / 58 54 24

www.willmes.de; e-mail: info@willmes.de

technische Änderungen vorbehalten / technical changes reserved /
Sous réserve de modifications techniques / modifiche tecniche riservate
Maßtoleranzen / dim. tolerances: L<4000mm: ±15mm; L>=4000mm: ±25mm
Zeichnung kann von definitiver Ausführung gem. Auftragsbestätigung abweichen
dessin peut différer de l'exécution définitif selon confirmation d'ordre
disegno può derogare del esecuzione definitivo secondo conferma d'ordine