

## Merlin 1200

Zch.-Nr.: / drw. no.: 58056 page 1 of 2  
 03.11.2020 B. Walther  
 Maßstab / scale (DIN A3): 1:30  
 sw-dat.: 58056-Merlin1200\_SW\_Standard\_MB

Ausführung / Softwanne auf Rollen, GE: 0  
 execution: juice tray on wheels  
 Bac à jus sur roues  
 Vasca mosto su ruote

Behältervolumen / Tank volume /  
 Volume de la cuve / Volume serbatoio: 1.140 Liter

Füllvolumen der Softwanne / Juice tray volume /  
 Bac à jus Contenu / Vasca mosto Capacità: 420 Liter

Leergewicht / Empty weight / Poids vide / Peso a vuoto:  
 externer Kompressor / Integrierter Verdichter  
 external compressor / integrated compressor  
 compressore esterno / compressore integrato 730\* / 800\* kg

### Willmes GmbH

Bensheimer Straße 101 - D-64653 Lorsch  
 Service-Nummer: +49 1805 / 58 54 24  
 www.willmes.de; e-mail: info@willmes.de

technische Änderungen vorbehalten / technical changes reserved /  
 Sous réserve de modifications techniques / modifiche tecniche riservate  
 Maßtoleranzen / dim. tolerances: L<4000mm: ±15mm; L>=4000mm: ±25mm  
 Zeichnung kann von definitiver Ausführung gem. Auftragsbestätigung abweichen  
 disegno può derogare del esecuzione definitivo secondo conferma d'ordine

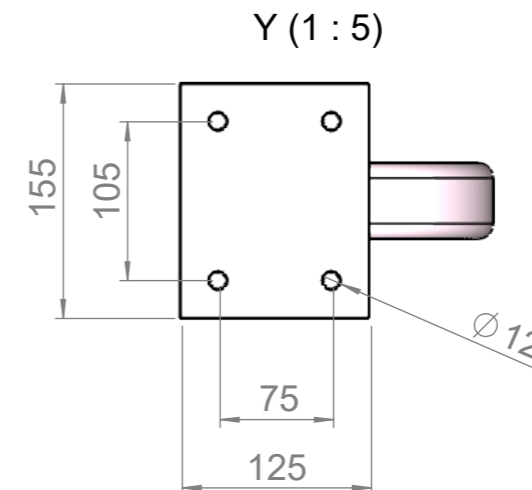
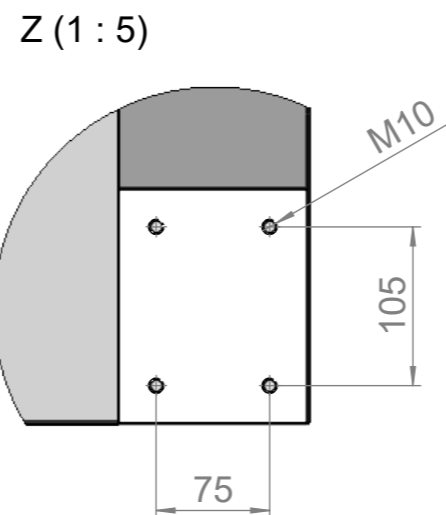
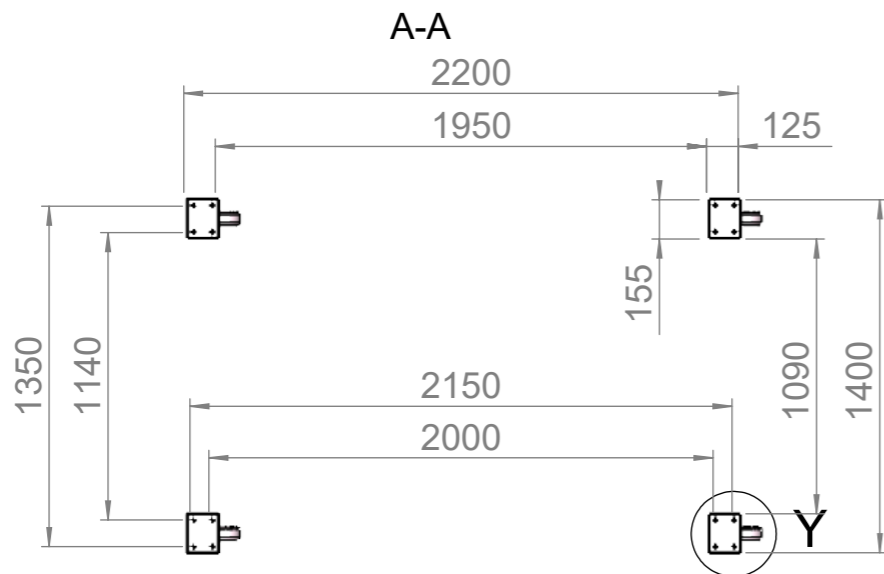
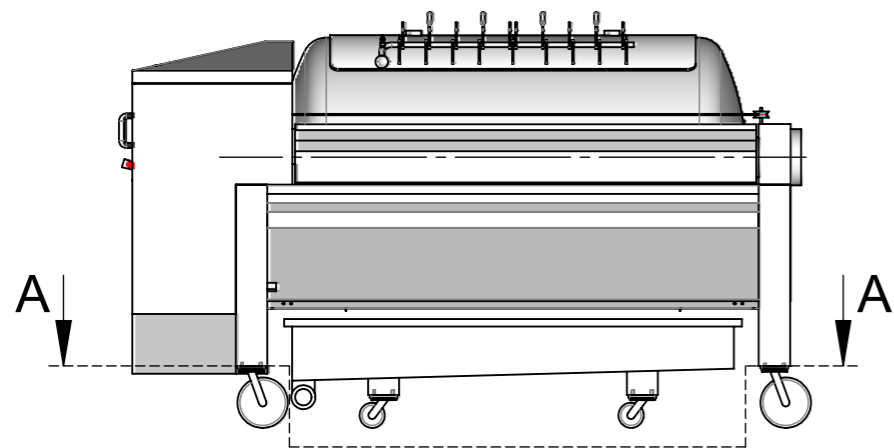
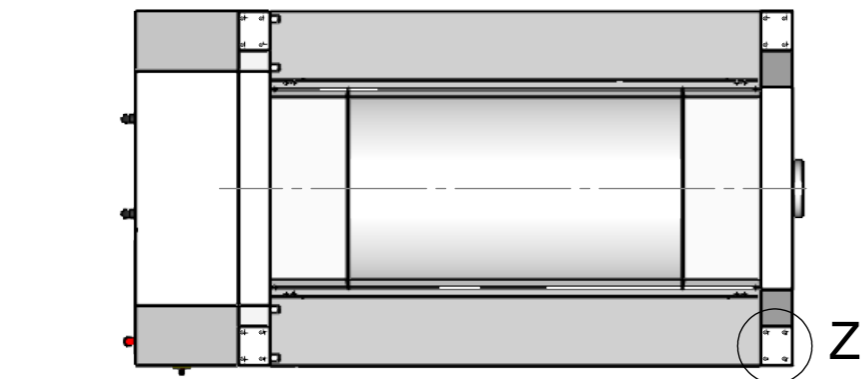

subject forces upon installation

part **Merlin 1200** without additional options, completely filled (water)!

**WILLMES**

Datum / date: 01.01.2021

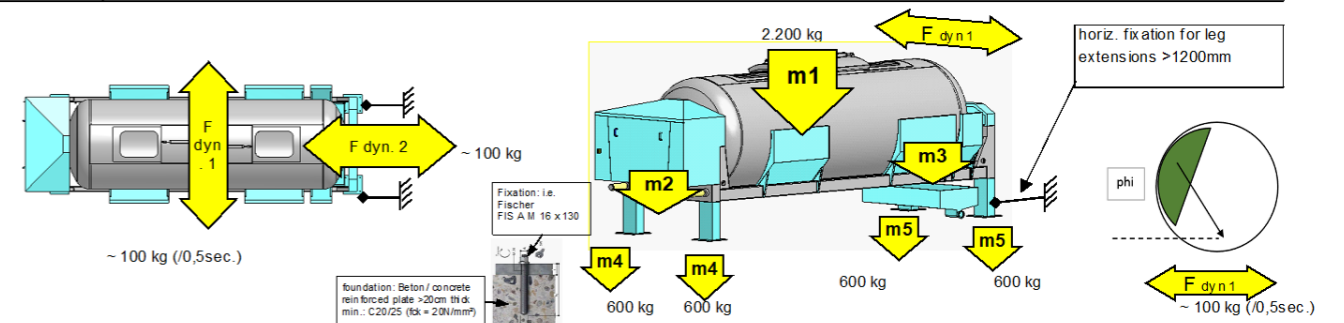

type of press **Merlin 1200**

Leergewicht Presse ca. / empty weight / poids vide (net) / peso vuoto della macchina: **800 kg**

Necessary condition for the installation and diverting of the forces of above-mentioned components plus the payload is a sufficiently rigid and horizontal ground. We assume that this condition is met by the customer. Unless otherwise stated, expenses for any required static or dynamic calculation for total installation is not included. Expenses for any necessary tests in accordance with the local regulations or local regulatory approvals are not included.

Parameter	Wert / value / valeur / valore	Beschreibung / description / descrizione / descrizione	Kraft / force / force / forza
m1	2.200 kg	Gesamtgewicht Presse + max. Füllung / total weight press + completely charged poids totale du pressoir + chargement / peso totale della pressa + caricamento	22 kN
m2	1.200 kg	Gesamtgewicht auf Antriebsseite / total weight drive end poids totale: côté moteur / peso totale: lato di motore	12 kN
m3	1.100 kg	Gesamtgewicht auf Gegenseite / total weight axial feed end poids totale: côté chargement axiale / peso totale: lato di alimentazione assiale	11 kN
m4 (2x)	600 kg	Gesamtgewicht pro Gestellfuß auf Motorseite / total weight per leg on drive end poids totale par pied au côté moteur / peso totale per piede al lato di motore	6 kN
m5 (2x)	600 kg	Gesamtgewicht pro Gestellfuß auf Gegenseite / total weight per leg on axial feed end poids totale par pied au côté chargement axiale / peso totale per piede al lato di caricamento assiale	6 kN
F <sub>dyn 1</sub>	~ 100 kg (0,5sec.)	approx. horizontal force on rotation (pomace cake, frequency: ~ 5 x / pressing x ~ 3 pressings / day x ~ 30 days / year = ~ 450x / year)	~ 0,9 kN (0,5sec.)
F <sub>dyn 2</sub>	~ 100 kg	ATTENTION: in the case of central filling, dynamic vibration may be caused by mash pump	~ 1,0 kN

## Merlin 1200

Zch.-Nr.: / drw. no.: 58056 page 2 of 2

03.11.2020 B. Walther

Maßstab / scale (DIN A3): 1:30

sw-dat.: 58056-Merlin1200\_SW\_Standard\_MB

Ausführung / Softwanne auf Rollen, GE: 0  
execution: juice tray on wheels

Bac à jus sur roues

Vasca mosto su ruote

Behältervolumen / Tank volume /  
Volume de la cuve / Volume serbatoio:

1.140 Liter

Füllvolumen der Softwanne / Juice tray volume /  
Bac à jus Contenu / Vasca mosto Capacità:

420 Liter

Leergewicht / Empty weight / Poids vide / Peso a vuoto:

externer Kompressor / Integrierter Verdichter  
external compressor / integrated compressor  
compressore esterno / compressore integrato

730\* / 800\* kg

**Willmes GmbH**

In der Dieterswiese 8 - D-64653 Lorsch

Service-Nummer: +49 1805 / 58 54 24

www.willmes.de; e-mail: info@willmes.de

technische Änderungen vorbehalten / technical changes reserved /  
Sous réserve de modifications techniques / modifiche tecniche riservate  
Maßtoleranzen / dim. tolerances: L<4000mm: ±15mm; L>=4000mm: ±25mm  
Zeichnung kann von definitiver Ausführung gem. Auftragsbestätigung abweichen  
dessin peut différer de l'exécution définitive selon confirmation d'ordre  
disegno può derogare del esecuzione definitivo secondo conferma d'ordine